

**Bar List**

Id.	Qty.	Size	Length	Form	Lbs.
Spr1	9	#5	3'-8"	Bnt.	34.45
Spr2	9	#5	4'-8"	Bnt.	43.84
Spr3	9	#5	3'-0"	Bnt.	28.16
L1	2	#4	2'-5"	Str.	3.23
L2	3	#4	9'-2"	Bnt.	18.38
L3	10	#7	6'-11"	Bnt.	141.45
H1	9	#4	7'-10"	Str.	47.07
H2	14	#4	5'-6"	Str.	51.44
H3	14	#6	5'-6"	Str.	115.65
Total Lbs.					483.67

**Quantities for Type 3 Light Pole Footing**

Structural Concrete = 5.41 C.Y./FTG.  
Reinforcing Steel = 484 LBS./FTG.

**Design Data**  
LOAD FACTOR DESIGN  
f'c = 3,000 psi, fy = 60,000psi.

**Quantities for Type 3 Light Pole Footing**

Item No.	Item	Unit
804(A)	Structural Concrete	CY
804(B)	Reinforcing Steel	LBS

- General Notes:**
- For luminaire base plate and anchor bolt material specifications and general notes, see Standards HLBP1-1 and Roadway Standard LECS-4 (Latest Revision).
  - Temporary blockouts are to be made in edge of pavement at safety barrier light pole footing, Type I and Type II, locations. Installation and removal of temporary blockouts to be paid for in other items of work.
  - Price bid shall include payment for materials, labor, pipe sleeves, expansion joints, expansion joint material and all incidentals necessary to complete the installation.
  - All construction and materials shall be in accordance with the 2009 Standard Specifications.
  - Any device for supporting dowels shall have sufficient rigidity and be so held in place during concrete placement that dowels will be in true position in the finished barrier wall. Any method or device not producing the desired results shall be discontinued.
  - All exposed edges shall have a 3/4" chamfer and all surfaces shall be finished in accordance with Section 509.04(0) of the Standard Specifications.
  - Sloped face parapet, see Bridge Standard SFP1-2 (Latest Revision) for more information.
  - All reinforcing steel shall be epoxy coated reinforcing steel, Grade 60.
  - 1 1/4" smooth dowel bars shall be placed in the blockout areas with sleeves facing out of the blockout. Blockout "B" shall not be constructed with parapet footing construction. The dowel bars shall be placed in the center of the parapet and footings at 12" C/C and shall have a shop or field coat of zinc chromate for the full length of the bar and shall have a field coat of MC-70 on the free end (Minimum 1/2 length of the bar). Air space in the end of the expansion cap to be 1" minimum and 2" maximum.
  - Junction box(es), rigid metal conduit, and non-metallic flexible conduit, when required, shall not be paid for directly, but will be considered subsidiary to the various items of work under Section 804, "Concrete Footings" for either a drilled shaft footing or spread footing.
- Sequence of Construction**
- Prepare dowel bars, sleeves and blockout "B" for construction of parapet footing (See Note 5, & 9).
  - Construct parapet footing.
  - Prepare dowel bars, sleeves and blockout "A" for construction of single face parapet (See Note 5, & 9).
  - Construct single face parapet.
  - Remove dowel bars from dowel sleeves and construct drill shaft.
  - Reset dowels in the dowel sleeves and construct blockout "B" area.
  - Reset dowels in the dowel sleeves and construct blockout "A" area.

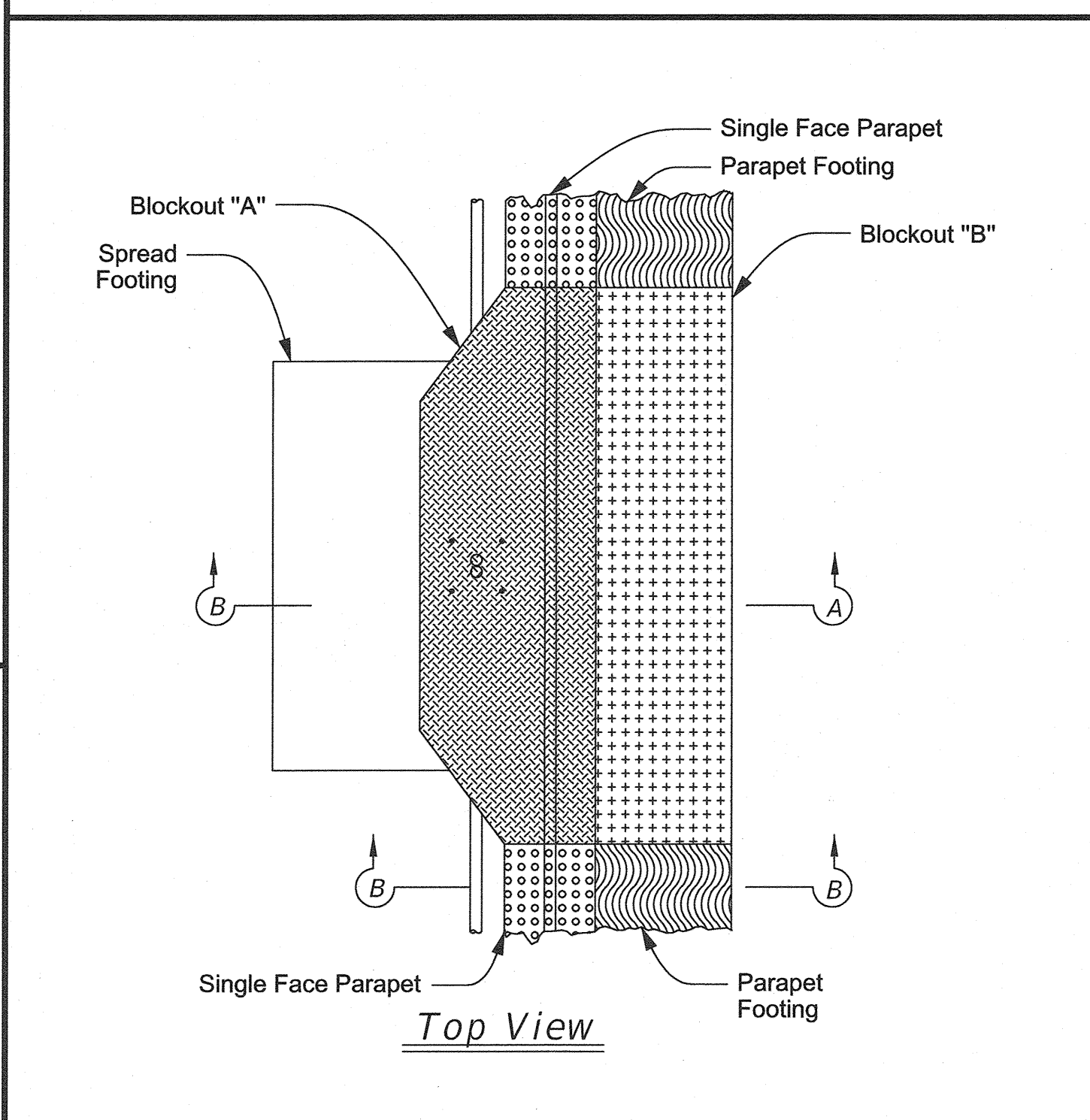

Approved By Bridge Engineer: *St. Am.* Date: 3-24-16

Approved By Traffic Engineer: *Hold Smith* Date: 3/10/2016

**DOT**

Traffic Standard Safety Barrier Light Pole Footing Details (Design No. 3)

2009 Specifications

BMF4-2 00

T-307